

DOEN DJ152-HYBRID

Hybrid option for DJ152

Responding to the ever-increasing demand for green solutions and zero emission offerings in the marine sector, Doen WaterJets is pioneering yet another waterjet propulsion first with the **DJ152-HYBRID**.

The DJ152-HYBRID readily couples with conventional marine diesels directly or via transmissions, in the same way as the standard DJ152 waterjet. The DJ152-HYBRID is however supplied with an integrated Power Take In (P.T.I) feature that connects a jet-mounted electric motor to drive the main waterjet shaft.

The DJ152-HYBRID provides three modes of operation:

- ✓ Electric Only,
- ✓ Diesel Only and
- ✓ Diesel + Electric (boost)

When in electric only mode the main diesel/s do not need to be running. The integrated electric motor is continuously rated at 15kW or 20kW output to provide for low speed operation with zero emission.

In the diesel only mode the waterjet will be driven by the main diesel engine for high-speed performance. Hence whilst in this mode, the electric motor can also be driven by the diesel for battery regeneration/charging.

Lastly, if need be the electric motor can be periodically operated in parallel to the diesel engine to supplement the output of the main diesel and boost the high speed performance of the vessel.

Scope of Supply - The DJ152-HYBRID is supplied ex factory with integrated P.T.I. device, electric motor, electric motor mounts and couplings to the waterjet. Additionally for electric motor control and operation each electric motor is supplied with a motor controller and cooling system. The motor controller allows for selection between output modes and regeneration mode.

Doen's ECS400 electronic control system provides overall propulsion control, mode selection and system status; seamlessly operating both the diesel and electric motors all by way of the same control levers and the station panel LCD touch screen.

Batteries and any shore power battery charging facility are **NOT** included in the scope of supply of the DJ152-HYBRID. It is recommended that these are directly sourced from a LiFePO4 supplier who offers specific marine rated batteries that are best suited to this application.

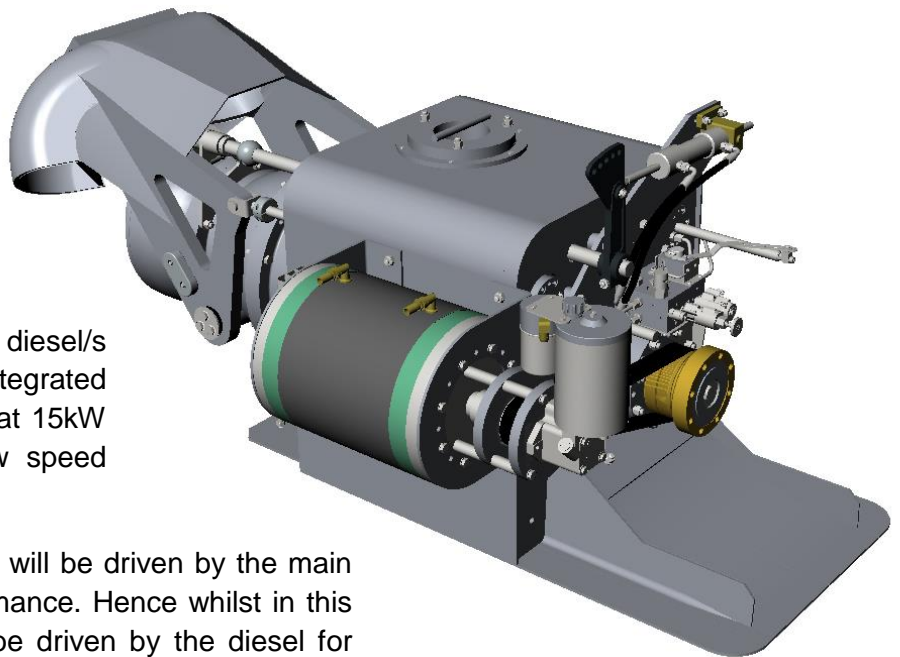

Performance Reliability Simplicity

UNIT DETAILS

Maximum Rec. diesel Power:	up to 670skW (900shp) ^(A)
Maximum Rec. Impeller speed:	2250rpm
Electric power input (integrated):	15kW (or 20kW optional)
Dry Weight:	870 kg (including jet mounted 15kW motor, PTI, hydraulics, etc.)
Entrained Water:	85 kg
Loss of buoyancy:	0.07m ³ (duct volume within hull bound)
Corrosion Protection:	Cathodic with Anodes
Design Standard:	To international authority standards

(A) Requires application approval by Doen WaterJets

CONSTRUCTION DETAILS

Impeller

Diameter:	15 inch (381mm)
No of Stages/Configuration:	Single Stage – Axial flow pump
Standard Rotation:	Anti-clockwise (Looking forward from stern)
Impeller Material:	Cast CF8M Stainless Steel

Pump Assembly

Impeller Casing Material:	Cast ASTM A356 Alum. Alloy with stainless steel liner
Discharge Nozzle Material:	Cast ASTM A356 Alum. Alloy

Steering System

Description:	Balanced nozzle
Operation:	Inboard tiller actuation
Steering Bowl/Nozzle Material:	Cast ASTM A356 Aluminium Alloy

Reverse System

Description:	Split Duct Type – “High Thrust”
Operation:	Twin Hydraulic cylinder actuation
Reverse duct material:	Cast ASTM A356 Aluminium Alloy

Shaft Assembly

Main Shaft Material:	Stainless Steel Grade SAF 2205
Rear Bearing:	Water Lubricated Cutlass Bearing
Main Bearing:	Angular contact Thrust Bearing
Lubrication:	Grease
Shaft Seal:	Face type Mechanical Seal
Coupling Flange:	DIN 180 _8 Bolt (other types available)
Shaft Angle:	0 degrees standard

Intake Body

Material:	Cast ASTM A356 Aluminium Alloy
Inspection Opening:	Outboard (Inboard option is available)
Intake Grate:	Removable Aluminium Bars